



# EG Series Screw Air Compressors

Life source of industries

**ELGI**  
Always Better.

**UPTIME**<sup>™</sup>  
ASSURANCE



CIN: L29120TZ1960PLC000351

[www.elgi.com](http://www.elgi.com)

90 - 160 kW / 125 - 200 HP

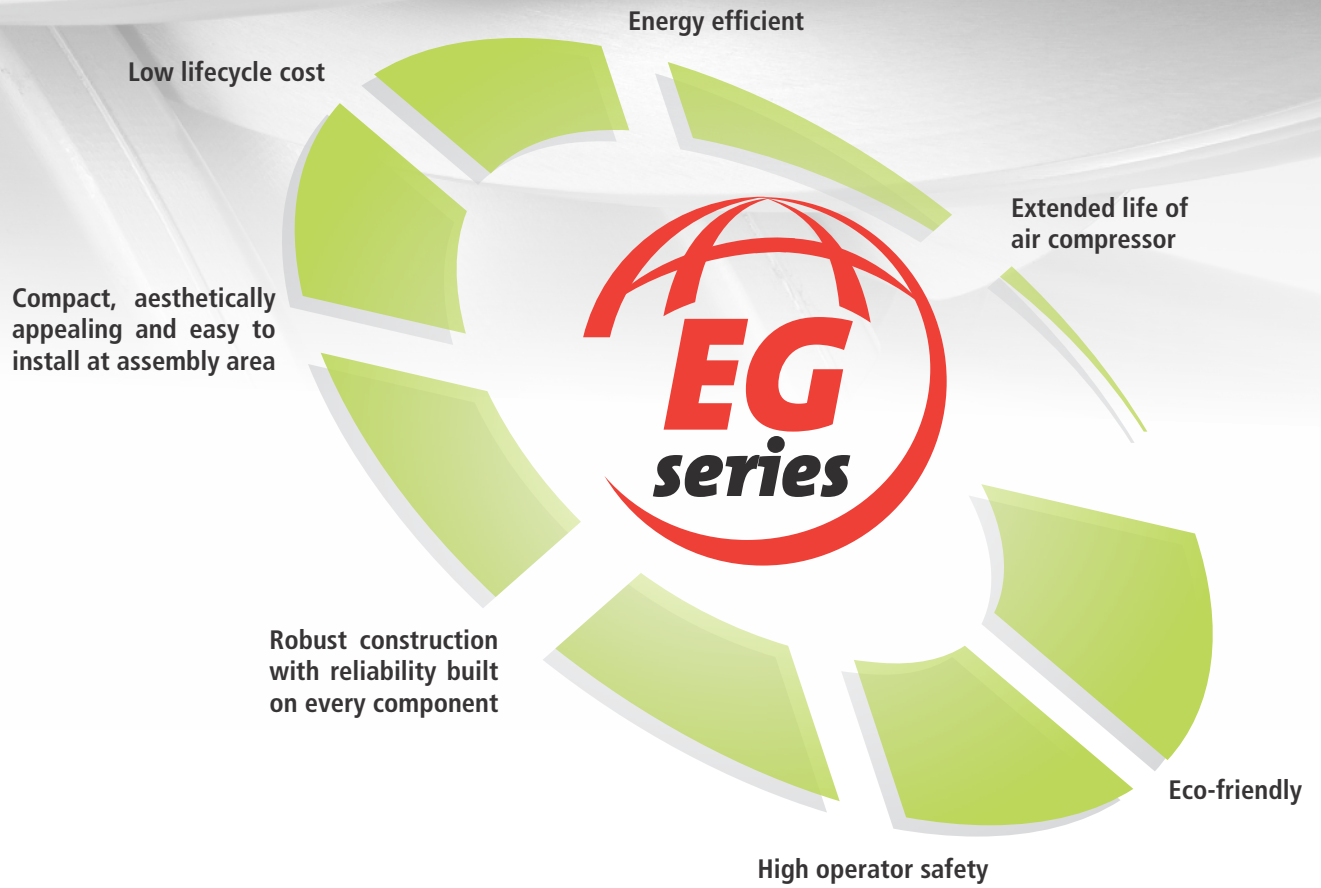

The EG Series compressors represent a giant leap in design and performance with each component designed for reliability and ease of maintenance. The compressor is manufactured in compliance with applicable international standards (UL, ASME, CE and others) and designed as per the international quality standards. These new generation compressors significantly reduce operating costs and provide cost savings with fast return on investment.

# High efficiency to cut down energy costs



EG Series Compressors provide high-quality compressed air in the harshest environmental conditions. Incorporating the next generation technology of ELGi's oil-injected screw element provides a long and trouble-free life at the lowest possible operating cost.

These compressors are designed, manufactured and tested in accordance with **ISO 1217**, which comes with an in-built Variable frequency drive that significantly reduces energy consumption and cost.

## MAXIMUM Energy efficiency

### Optimal flow control

- The new generation intake valve with integrated blow down unit, solenoid switch and actuator is designed for low losses
- The intake valve is optimized for dual mode operations
- Optimum size of the intake valve minimizes pressure drop and suction losses
- Modulation unit ensures effective control of inlet air flow and maximizes power savings
- Auto dual control operates on modulation mode from 100-60% in loading and in load-unload mode for loads below 60%
- Constant pressure due to gradual opening or closing of suction valve with respect to demand (multi-point) control
- Option for selecting load-unload/modulation auto dual mode for all large screw compressor models as a standard feature
- Smooth operation by modulation ensures longer life of airend, valves and all mechanical components. It also ensures no sudden spikes or drop in line pressure
- Lowest power consumption in its class of compressor controls, even with fluctuating loads

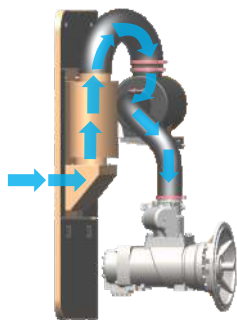
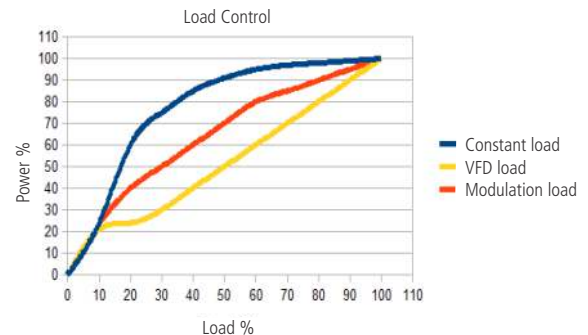

### Efficient air filter system

- Use of pre-filters ensure clean air suction unit and enhances air filter life cycle
- Heavy duty dry type air filter ensure two ways of filtration by centrifugal action and by paper filter cartridge with 99.9% efficiency
- Optimally sized high efficiency filter provides maximum filter life and clean intake air
- Air filter with visual condition indicator for easy maintenance of the system
- Automatic cleaning of air filter for every cycle of upload operations



### High efficiency drive system

- Heavy duty TEFC squirrel cage induction motor with class F insulation and IP55 protection for assured operation in dusty environment
- Wide operating voltage +/- 10%
- Motor selected for high ambient of 45°C with power variants 415V/400V/380V in 50 Hz
- Motor winding temperature limited to Class B temperature rise
- Optimized ventilation system for cooler operations and reduced noise levels
- Solid base for reduced vibration levels
- Regreasable ball bearings
- Gasket for conduit box



## Drive coupling

- Ensures efficient power transmission with uniform load on bearing due to permanent alignment of airend and motor
- Easy serviceability and replacement of the coupling element without dismantling the drive system



## MAXIMUM Performance

### Efficient air-oil separation

OSBIC design

The efficient air-oil separation by OSBIC (Oil Separation By Impact and Centrifugal action) enables efficient separation of air and oil, with minimum pressure drop. The method enables separation of oil in three stages, delivering consistent oil-free air while increasing the life of separator element

Stage 1: Impact of air-oil mixture on the radial baffle plate reduces kinetic energy

Stage 2: Centrifugal action of air-oil mixture (spin down action) to shed of the oil particles

Stage 3: Air with minor traces of oil will enter the air-oil separator element placed inside the tank to purify the air (residual oil carry over level is 1ppm)

- Smaller oil volume with industry lowest refill requirements
- ASME design and CE/GB certified
- Minimum pressure drop in tank
- Leak proof flanges with O-rings ensure leak free connections



### Integrated moisture separator as standard feature

- Designed to handle high humid compressed air outlet from after-cooler
- 99% of bulk water removal by Impact and Centrifugal action with minimum pressure drop and automatic discharge of collected water particles by float mechanism

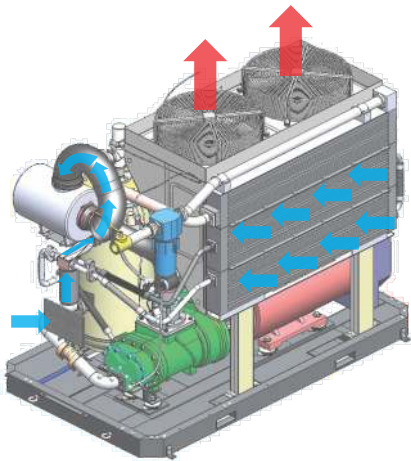

### Efficient air cooling

- The compressor is designed to operate in wide temperature range from 0°C to 45°C with a very low after cooler approach temperature
- Sucker type, quiet and high capacity cooling fans reduce the input power while ensuring efficient cooling air flow
- Unique cooling air path for aftercooler by means of closed air duct which separates cooling system from rest of the unit
- Easy access to cooler cleaning ensures fast maintenance and improves reliability

## How loud is too loud?

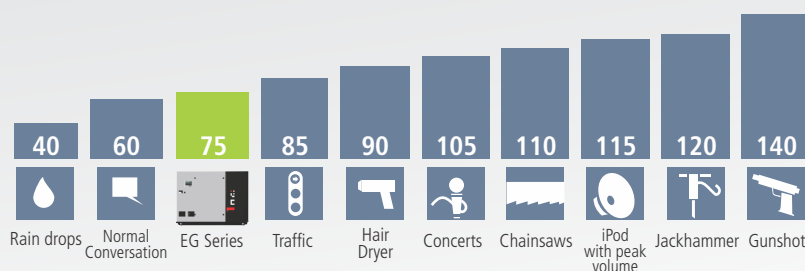



## Performance Control System

- Built-in Dryer Dew Point integration
- VFD Parameter (Power, HMR, Frequency, Ampere, Voltage)
- Read out and closed loop control
- Selectable AO (Pressure/Temperature/Dew Point) for DCS integration



## Reports

- Cumulative Report (Run Hours, Load Hours, Unload Hours, Stop Hours, Fault Hours and remaining AFCT, OFCT, OSCT, OCT and RGT)
- Detail Report - Previous 15 Days (Load Hours, Unload Hours, Stop Hours, Fault Hours, and Number of times machine stopped due to standby)
- Fault Report - (Previous 99 Faults in chronological order with Real Time stamping and type of fault)



## Remote Monitoring

- **DCS (MODBUS RTU/RS 485):** controller is enabled to synchronize with distributed control system - control of compressor from control panel of customer
- **SCADA :** compressor control through PC with remote monitoring by supervisory control and data acquisition process



## Safety and Protection

Global Series compressors are designed and perfected to ensure highest level of safety for

- Pressure regulating valve
- High pressure
- High temperature
- Pressure relief valve
- Phase order and single phase



## ELGi Airmate Accessories



### Refrigeration air dryer

Flow Range: 400~1250 cfm  
Working Pressure: 100-190 psig  
(7-13 bar g)



### Airmate downstream filter

Air Flow : 35-3,200 cfm (1-90 m<sup>3</sup>/min)  
Working Pressure : 100-190 psig  
(7-13 bar g)  
Filtration Range : 1-0.003 microns



### Airmate air receiver

Capacity: 250-10000 ltrs  
Working Pressure: 100-190 psi g  
(7-13 bar g)  
Code of Construction: ASME  
sec. VIII Div.I or IS 2825



### Drain valves

Timer controlled and zero loss  
Capacity : 50 to 2000 cfm  
Working Pressure : 100-190 psig (7-13 bar g)

# Energy Saving - The CONSERVE Way

## In-Built ELGI **CONSERVE™** Variable Frequency Drives (VFD)

Matches compressor output with demand by varying motor speed. The power consumption reduces in line with the reduction in demand. This Helps in eliminating the frequent load-unload cycle and also the wasted power from the energy bill.

A fixed speed compressor operates on a load unload band of at least 10 psi around the working pressure whereas with ELGi VFD, compressor can be operated within a band of 2 psi. Since the compressor is not operated under higher than working pressure requirements, there is substantial energy saving. For every 2 psi reduction in operating pressure, there is 1% power saving.

In a fixed speed compressor with Star-Delta starter, starting current is as high as three times the full load current (FLC). With ELGi VFD starting, starting current is less than the FLC. This helps to avoid using heavy rated components like fuses, MCCB, cable size, generator rating, isolators etc.

For compressed air systems with fluctuating demand pattern, giving a fast return on investment .



### Advantages:

#### Electrical:

- Low starting current
- High efficiency
- Improved power factor
- Reduced maximum demand

#### Mechanical:

- Minimum maintenance
- Smooth start
- Smooth control

### 10 Year Life-Cycle Cost

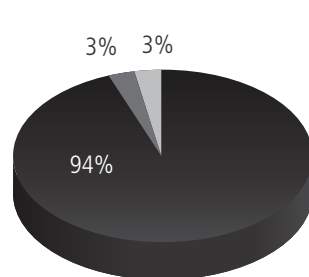

Compressor without VFD

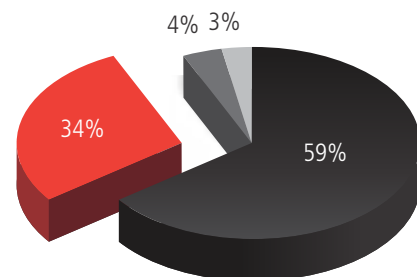

Compressor with **CONSERVE™**

■ Electricity Cost ■ VFD Saving ■ Equipment Cost ■ Maintenance Cost

## After Sales Solutions

A wide range of after sales products and services is designed to add maximum value for our customers. Our fast serviceability ensures optimum availability and reliability of the compressors with the lowest possible operating costs.

### Genuine spares and service

ELGi Genuine Spares helps in avoiding unexpected compressor failures and the risk of consequential damage to other vital compressor components. ELGi spares are designed, manufactured and checked for quality to meet the standards of a new compressor. The spares undergo continuous improvement to provide best results and are available through the vast network of ELGi dealers in India and International markets.

## Air-Oil Flow Diagram

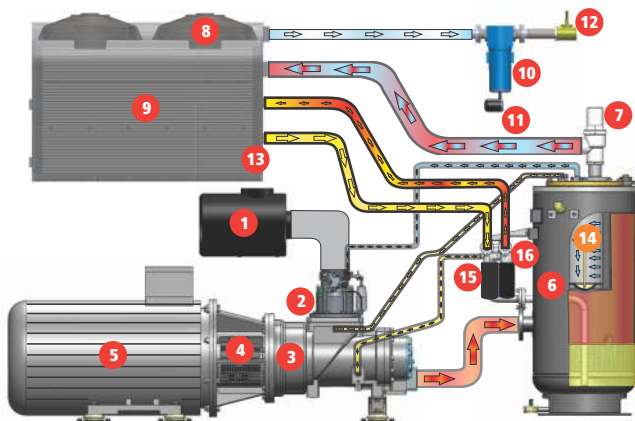

1. Air intake filter
2. Suction control valve
3. Airend
4. Drive coupling
5. Electric motor
6. Air-oil separator tank
7. Minimum pressure valve
8. Cooling fan
9. After cooler
10. Moisture separator
11. Automatic drain
12. Outlet valve
13. Oil cooler
14. Air-oil separator
15. Oil filter (spin-on)
16. Thermal valve unit

- COOLED AIR
- HOT AIR
- COOLED OIL
- HOT OIL
- HOT AIR/OIL MIXTURE

# Technical Specification

Model	Motor Power		Working Pressure		Maximum Pressure		Free Air Delivery		Weight*	Noise Level
	50 Hz	kW	HP	bar g	psi g	bar g	psi g	m <sup>3</sup> /min		
<b>Dimensional Data L(Length) x W(Width) x H(Height) in mm 2830 x 1640 x 2125</b>										
EG 75	75	100	4.5	65	5.5	80.0	16.7	590	2700	75
EG 90	90	125	7.0	102	8.0	116.0	16.6	585	2700	75
EG 90	90	125	8.0	116	9.0	130.5	15.2	538	2700	75
EG 90	90	125	10.0	145	11.0	159.5	13.3	470	2700	75
EG 90	90	125	4.5	65	5.5	80.0	19.9	706	3100	75
EG 110	110	150	7.0	102	8.0	116.0	19.8	706	3100	75
EG 110	110	150	8.0	116	9.0	130.5	18.4	649	3100	75
EG 110	110	150	10.0	145	11.0	159.5	16.4	580	3100	75
EG 110	110	150	4.5	65	5.5	80.0	24.3	858	3400	75
EG 132	132	175	7.0	102	8.0	116.0	24.2	855	3400	75
EG 132	132	175	8.0	116	9.0	130.5	22.4	791	3400	75
EG 132	132	175	10.0	145	11.0	159.5	20.1	710	3400	75
EG 132	132	175	4.5	65	5.5	80.0	29.1	1030	3700	75
EG 160	160	200	7.0	102	8.0	116.0	29.1	1026	3700	75
EG 160	160	200	8.0	116	9.0	130.5	27.0	954	3700	75
EG 160	160	200	10.0	145	11.0	159.5	24.05	850	3700	75

## Technical Specification (VFD model)

Model	Motor Power		Working Pressure		Maximum Pressure		Free Air Delivery		Weight*	Noise Level
	50 Hz	kW	HP	bar g	psi g	bar g	psi g	m <sup>3</sup> /min		
EG 90	90	125	7	102	7.5	108.5	14.07 ~ 16.7	235 ~ 590	2765	75
EG 90	90	125	8	116	8.5	125.0	6.59 ~ 15.2	233 ~ 538	2765	75
EG 90	90	125	10	145	10.5	152.5	6.31 ~ 13.3	223 ~ 470	2765	75
EG 110	110	150	7	102	7.5	108.5	7.87 ~ 19.9	278 ~ 701	3165	75
EG 110	110	150	8	116	8.5	125.0	7.75 ~ 18.4	274 ~ 649	3165	75
EG 110	110	150	10	145	10.5	152.5	7.75 ~ 16.4	274 ~ 580	3165	75
EG 132	132	175	7	102	7.5	108.5	10.00 ~ 24.2	353 ~ 855	3465	75
EG 132	132	175	8	116	8.5	125.0	9.85 ~ 22.4	348 ~ 791	3465	75
EG 132	132	175	10	145	10.5	152.5	9.65 ~ 20.1	341 ~ 710	3465	75
EG 160	160	200	7	102	7.5	108.5	11.60 ~ 29.1	411 ~ 1026	3820	75
EG 160	160	200	8	116	8.5	125.0	11.75 ~ 26.5	415 ~ 935	3820	75
EG 160	160	200	10	145	10.5	152.5	11.55 ~ 24.05	408 ~ 850	3820	75

### Note:

- Free Air Delivery(FAD) is tested as per ISO 1217 : 2009 Annexure C Edition: 4
- All models are available in air-cooled and water-cooled variants
- Max pressure or unload pressure of all standard models is 1 bar above the working pressure
- Max pressure or unload pressure of all VFD models is 0.5 bar above the working pressure
- FAD indicated is for the full package measured at the outlet after moisture separator
- Sound level measured as per ISO 2151, Second Edition at 1m distance in field conditions, +/-3dB(A)
- Due to continuous engineering improvements, the specifications are subject to change without prior notice

# Compressed air solutions for all sustainable air needs



**Oil-Free Series Screw**  
90 - 450 kW / 480 - 2515 cfm



**EG Series Rotary Screw**  
11 - 250 kW / 47 - 1612 cfm



**EN Series Rotary Screw**  
2.2 - 75 kW / 8.0 - 469 cfm



**Electric Portable (Trolley)**  
22 - 75 kW / 131 - 490 cfm



**Diesel portable (Trolley)**  
185 - 1100 cfm / 100 - 300 psi



**Diesel Portable (Skid)**  
475 - 1500 cfm / 150 - 400 psi



**Oil-free Recip**  
1.0 - 75 HP / 1.8 - 300 cfm



**Oil-lubricated Recip**  
1.0 - 40 HP / 2.0 - 128 cfm

## OVERSEAS OFFICES:

**Bangladesh :** ELGI Equipments Limited, 5th Floor, Planners Tower, Level: 5 Suite: 8-13, 13/A Bir Uttam CR Datt Road, Sonargaon, Dhaka-1000. Bangladesh.  
**T:** 880-9671453-65, **F:** 880-28616148, **E:** bangladesh-enquiry@elgi.com

**Malaysia :** ELGI Equipments Limited, No 2A-4-6, Jalan Jubli Perak, 22/1, Section 22, 40400, Shah Alam, Malaysia, **T:** +603 55693544, **F:** +603-55693544,  
**E:** malaysia-enquiry@elgi.com, **w:** www.elgi.com.my

**Srilanka :** S.G. Arcade, 2nd Floor, No.441, Sri Sangaraja Mawatha, Colombo-10, **T:** 00 - 94-11-2392425, **F:** 00-94-11-4737412. **E:** elgisupport@slnet.lk

**Thailand :** ELGI Equipments Limited, 223/66 Country Complex A 14th Floor, Sanphawut Road, Bangna Bangkok - 10260. **T:** +6627455160  
**E:** thailand-enquiry@elgi.com, **w:** www.elgi.co.th

## WHOLLY OWNED SUBSIDIARIES

**Australia :** ELGI Equipments Australia Pvt Ltd., 38. Richland Avenue, Coopers Plain QLD 4108 Australia. **T:** +61-7-3106 0589, **F:** +61-7-3106 0537,  
**E:** Enquiry@elgi.com.au, **w:** www.elgi.com.au

**Brazil :** ELGI Compressores Do Brasil Ltd., Av. Emilio Checchinato, 4195 - B: Cep : 13295 - 000, Bairro: Sao Roque da Chave: Itupeva - SP, Brazil.  
**T:** 4496 5519, 4496 6611, **E:** contacto@elgi.com.br, **w:** www.elgi.br

**China :** **ELGI Equipments (Zhejiang) Limited**, No.232, Yunhai Road, Economic Development Zone, Jiaxing 314033 P. R. China **T:** +86-573-82079100  
Hotline: 400-826-3585 | **ELGI Compressors Trading (shanghai) Co. Ltd.**, Rm 909, LSHQ International Centre, 288 Hongjing Road, Shanghai 201103, P. R. China  
**T:** +86-21-33581191 Hotline: 400-826-3585, **E:** enquiry.cn@elgi.com, **w:** www.elgi.com.cn

**Indonesia :** PT ELGI Equipments Indonesia, Kawasan Pergudangan, BIZPARK Commercial Estate, Pulogadung Jl. Raya Bekasi KM 21, 5 Blok A3 No. 12, Kel. Rawa Terate, Kec. Cakung, Pulogadung Jakarta Timur 13920. **T:** +62-21-46822216, 46827388, **E:** indonesia-enquiry@elgi.com, **w:** www.elgi.co.id

**Italy :** ELGI Compressors Italy S.r.l., Rome(RM), Via Del Babuino 51, 00187 : ROTAIR Spa, Via Bernezzo 67, 12023 Caraglio (CN), Italy. **T:** +39 0171619676,  
**F:** +39 0171619677, **E:** info@rotairspa.com

**Middle East :** ELGI Gulf (FZE), P.O. Box: 120695, Q4-081, SAIF Zone, Sharjah, U.A.E. **T:** +971 6 557 9970, **F:** + 971 6 557 9980, **E:** gulfenquiry@elgi.com

**USA :** ELGI Compressors USA, Inc. 1500-N Continental Blvd, Charlotte, NC 28273. **T:** +1-704-943-7966, **M:** +1-803-427-7985, **W:** www.elgi.us

# ELGI

**ELGI EQUIPMENTS LIMITED**

**CORPORATE OFFICE:** Trichy Road, Singanallur, Coimbatore - 641005,

**T:** +91-422-2589555, **E:** enquiry@elgi.com, **w:** www.elgi.com

Customer care mobile no.: +91 92821 11224 (SMS only)

Toll-free no: **1800-425-3544** (applicable for India only)

Distributed by

